

## Who is Friends with Whom? Patterns of Inter- and Intraethnic Friendships of Mainstream and Immigrant Early Adolescents in Germany

**Maja K. Schachner**

University of Potsdam, Germany  
Tilburg University, Netherlands  
(maja.schachner@unipotsdam.de)  
(m.schachner@uvt.nl)

**Fons J. R. Van de Vijver**

Tilburg University, Netherlands  
North-West University, South Africa  
University of Queensland, Australia

**Alaina Brenick**

University of Connecticut, US

**Peter Noack**

Friedrich Schiller University Jena, Germany

### Abstract

Multiethnic schools provide opportunities for interethnic contact and the development of positive interethnic relations. Yet, some children develop such relations more easily than others. In the present study, we were interested in patterns of inter- and intraethnic friendships and the relative likeability of certain ethnic groups in ethnically heterogeneous schools. The sample comprised 842 early adolescents ( $M_{age} = 11.50$  years,  $SD_{age} = .71$ ; 53% male) from 64 countries of origin who attend multiethnic schools in Southwest Germany. In line with our expectations, interethnic friendships are to a large extent formed on the basis of cultural distance, with more friendships occurring between groups that are culturally more similar. Further, the likeability of children from different ethnic groups follows the so-called ethnic hierarchy, a rank order of different ethnic groups, which is based on perceived similarity with the mainstream group. Interventions to improve early adolescents' interethnic friendships should aim to reduce perceptions of cultural distance and ethnic hierarchies in intergroup settings.

### Introduction

Even in culturally diverse societies, members of different ethnic groups often do not mix a lot, leading separate lives in different residential areas. In this context, schools provide valuable opportunities for interethnic contact and the formation of friendships across cultural and ethnic boundaries. Yet, despite the opportunity for interethnic contact, the preference for friends who are similar is strong. This phenomenon is called homophily (McPherson, Smith-Lovin, & Cook, 2001). Interethnic friendships

are therefore less common, less stable over time, and often less intimate than intraethnic friendships (Aboud, Mendelson, & Purdy, 2003; Jugert, Noack, & Rutland, 2012). Further, some groups, such as Muslim immigrants in Europe, experience a high level of stigmatisation and discrimination, both by members of the national majority and other minority groups (Güngör, Fleischmann, Phalet, & Maliepaard, 2013). Early adolescence marks a particularly sensitive period in terms of the development of interethnic relations (Killen & Rutland, 2011). Studying early adolescents' friendship preferences in multiethnic schools is therefore an important step in order to understand the mechanisms that should be targeted to create sustainable multicultural societies. Most previous research on interethnic friendships included only a few large groups, often focussing on friendships between mainstream and immigrant children. Research including many different groups and also studying interethnic friendships between children representing different immigrant groups is still scarce. Against the background of Social Identity Theory (Tajfel & Turner, 1986) and the concept of perceived cultural distance (Galchenko & Van de Vijver, 2007; Hagendoorn, 1995), the aim of this study is to explore the specific patterns of friendships between different ethnic groups in multiethnic schools and the relative likeability of children from these different groups.

### Interethnic Relations as a Function of Similarity and Status

Similarity is one of the core principles underlying the formation of social relationships (McPherson *et al.*, 2001). This has also been found for children's friendships (Aboud *et al.*, 2003). Children's first preference is to have friends from their own ethnic group. A higher number of in-group members in the classroom has therefore been associated with higher levels of friendship homophily (Bellmore, Nishina, Witkow, Graham, & Juvonen, 2007; Titzmann, Brenick, & Silbereisen, 2014). When relationships are formed across ethnic boundaries, the degree of cultural similarity – or the opposite, perceived cultural distance (*i.e.* perceived differences in values, attitudes and beliefs) – plays an important role. For immigrants, a higher perceived cultural distance between the culture of origin and the host country makes it more difficult to adapt to a new country and establish relationships with members of the mainstream society. This has been shown for adult (Galchenko & Van de Vijver, 2007) and adolescent immigrants (Phalet & Hagendoorn, 1996). Baerveldt and colleagues found that in a classroom context with a higher share of immigrants from countries which are culturally more similar, the likelihood of friendships between immigrant and non-immigrant children was higher than in a context with a high share of immigrants from culturally more distant backgrounds (Baerveldt, Zijlstra, De Wolf, Van Rossem, & Van Duijn, 2007). Schachner and colleagues found that perceived cultural distance significantly predicted early adolescent immigrants' and non-immigrants' intention to befriend each other as well as actual friendships between these groups (Schachner, Brenick, Noack, Van de Vijver, & Heizmann, 2014).



Taking an intergroup perspective on social relationships, individual and group status have been identified as additional principles driving relationships between members of different groups. Social Identity Theory is based on the assumption that individuals gain self-esteem and personal status from being a member of a social group (Tajfel & Turner, 1986). One's personal status is therefore also dependent on the status of one's group. Thus, giving preference to members of one's own group over members of other groups can also be motivated by a desire to maintain or even enhance the status of one's group. According to Social Identity Theory, intergroup behaviour can be explained as a function of relative group status, the stability and legitimacy of status differences between groups and the permeability of intergroup boundaries (Tajfel & Turner, 1986). In order to enhance their personal status and gain self-esteem, individuals belonging to lower status groups can choose from a range of strategies. If group boundaries are permeable, they may decide to become part of a higher status group. If these boundaries are not permeable, they may try to enhance the status of their own group. Especially if status differences are perceived to be illegitimate and the lower status group is being discriminated against, this can enhance identification with the lower status group (Branscombe, Schmitt, & Harvey, 1999). At the same time, members of higher status groups may be reluctant to engage with members of lower-status groups in order to preserve their status.

Perceived cultural distance from the mainstream culture can also be a source of status differences between different ethnic groups in a society (Hagendoorn, 1995). In a so-called ethnic hierarchy, different ethnic minority groups can be ranked in terms of their status in the mainstream society, which corresponds to their degree of perceived cultural distance from the mainstream culture. This order appears to be agreed upon by members of different ethnic groups. Groups at the bottom of the status hierarchy tend to be most rejected (Verkuyten, Hagendoorn, & Masson, 1996). Previous studies revealed that early adolescents and even children are already aware of this hierarchy, with those from lower ranking groups reporting to be more discriminated against by peers (Verkuyten, 2002; Verkuyten *et al.*, 1996). In Germany and many other European countries, Muslim immigrants are highly stigmatised and rank at the bottom of the ethnic hierarchy (Hagendoorn, 1995; Jäckle, 2008). Accordingly, adolescents with a Muslim background experience high levels of ethnic discrimination and social exclusion (Güngör *et al.*, 2013). Immigrants from Eastern Europe on the other hand are considered a high status immigrant group. In Germany, many Eastern European immigrants are actually the descendants of German families who settled in the area of the former Soviet Union in the 19th century- an ancestral connection that warrants special rights in the naturalisation process but also implies some cultural and physical similarities with members of the German mainstream society.

Taken together, similarity and status are both relevant in the study of interethnic relations. Although these factors cannot be studied independently, they might elicit slightly

different processes, which have to be considered when interpreting patterns of inter- and intraethnic friendships.

### The present study

Our aim was to provide a more detailed picture of intra- and interethnic friendship patterns and the relative likeability of different ethnic groups in multiethnic schools. Although there has been an increasing interest in cross-ethnic friendships in recent years, the majority of studies differentiates only between a single majority and minority group and there are still very few studies looking into networks between a range of specific ethnic groups (see Windzio & Wingers, 2014, for a recent exception).

Against the theoretical background presented above, we can formulate specific hypotheses about the friendship patterns that we expect to see:

*Hypothesis 1:* More friendships will be observed between groups that are culturally closer to one another.

*Hypothesis 2:* The overall likeability of different ethnic groups will follow the order of the ethnic hierarchy. Following from this, we also expect that children from higher status groups will show higher levels of friendship homophily (*hypothesis 2a*) and that there will be more friendship nominations going from immigrant to German children than the other way round (*hypothesis 2b*).

## Method

### Participants

Our sample includes 842 students, of whom 490 have an immigrant background ( $M_{age} = 11.59$  years,  $SD = .74$ ; 52% male) and 352 are ethnically German ( $M_{age} = 11.38$  years,  $SD = .65$ ; 54% male). The majority of children with an immigrant background ( $N = 425$ ) were either born in Germany or migrated when they were very young ( $M = 4.39$  years,  $SD = 3.55$ ). Altogether they represent 64 different countries of origin.

### Procedure

Children were surveyed as part of a larger study on acculturation and intergroup relations in the school context. We targeted culturally diverse schools that represented the three main secondary school tracks in Germany (low and medium vocational tracks and high academic track). Participation was voluntary and subject to permission from school authorities and active parental consent. Participation rates were high, with 90% of the immigrant students and 89% of the non-immigrant students completing the survey in the participating classrooms.

### Measures

Measures used in this study included basic demographic information (sex, age, religion, and ethnicity) as well as measures of socioeconomic status, perceived cultural distance, and questions about children's friendships within the classroom. Only the mea-



asures of children's friendships and the information about children's own as well as their friends' ethnicity were used in the analyses of friendship patterns, whereas the other variables were used for descriptive statistics of the overall sample and the different ethnic groups.

*Socioeconomic status.* Children's socioeconomic status (SES) was measured by the number of books in the household, from (1) *none or very few* to (5) *more than 200 books*, as a measure of the educational background of the family (e.g., Bos *et al.*, 2003), and the Family Affluence Scale (FAS; Boyce, Torsheim, Currie, & Zambon, 2006; German version by Richter & Leppin, 2007). The FAS comprises three items, asking about the number of cars in the household – (0) *none*, (1) *one*, or (2) *two or more*, whether the child has his or her own room – (0) *no* or (1) *yes*, and how many times the family has been on holiday during the past year – (0) *not at all*, (1) *once*, (2) *twice*, or (3) *three times or more*. Both measures are frequently used in this age group. As recommended for such indices (Vyas & Kumaranayake, 2006), a single factor was extracted in a principal component analysis, which explained 36% of the total variance (individual item loadings between .45 and .79).

*Perceived cultural distance.* Different scales were used for immigrant and non-immigrant children. Immigrant children rated the perceived distance of their culture of origin compared to the German culture. Six items were adapted from Galchenko and Van de Vijver (2007) and tapped into private and public life domains (Arends-Tóth & Van de Vijver, 2007), such as general way of life, family life, parenting styles and dress (e.g., “How similarly or differently do people dress in Germany and your other country?”). Responses on a 5-point Likert scale ranged from (1) *very similar* to (5) *very different*. A single factor structure with good reliability ( $\alpha = .86$ ) was confirmed. German children were asked about the perceived cultural similarity between the German culture and the culture of the largest immigrant groups in Germany (later reverse coded as a measure of distance) using items adapted from Te Lindert and Van de Vijver (2010). Children rated how much they have in common with children from Turkey, Southern Europe, former USSR, former Yugoslavia, Eastern Europe, Asia, and other Western Countries, listing the most well-known exemplary countries in parentheses where applicable (e.g., “How much do you have in common with children from Southern Europe (e.g., Italy, Portugal, Greece)?”)¹. Responses on a 5-point Likert scale ranged from (1) *almost nothing* to (5) *a lot*. A single factor with good reliability ( $\alpha = .81$ ) could be extracted and the (reversed) mean score was used as a general measure of perceived distance between German and immigrant children.

*Children's friendships within the classroom.* Children were asked to list their five best friends in the classroom. We could then match participants' own demographic information (sex, ethnicity) with the information self-reported by the friends on their own

¹Items are based on the largest immigrant groups in Germany according to national statistics (Statistisches Bundesamt, 2013). These groups do not correspond with the regional groups, which were later formed to categorise our participant

questionnaires. This procedure has also been used in other recent studies (e.g., Hamm, Brown, & Heck, 2005; Vervoort, Scholte, & Scheepers, 2011) and is less prone to problems like social desirability or children not knowing the ethnicity of their friends.

## Results

### Data Preparation and Sample Descriptives

As some of the 64 countries of origin are only represented by very few children and in order to make the number of cultural groups more accessible for statistical analysis, we grouped children into 10 different regions. Regions were formed on the basis of cultural and religious aspects (e.g., Islam in Middle East and North Africa, Catholicism in Southern Europe; Central Intelligence Agency, 2012) as well as the immigration history (e.g., guest workers from Southern Europe, refugees from the former Yugoslavian countries on the Balkan; OECD, 2006). Germany and Turkey were the only countries making up a region on their own due to the large number of participants from both countries. Descriptive statistics by region, including a combined index for the family's socioeconomic standing (affluence and education), religious composition as well as the average level of perceived cultural distance, are displayed in Table 1.



Table 1

## Descriptive Statistics Individual Level by Region of Origin

Region	N	M <sub>age</sub> (SD)	M <sub>SES</sub> (SD)	% Male	% Christian	% Muslim	% No religion	M <sub>PCD</sub> (SD) <sup>a</sup>
Germany	352	11.38 (.65)	.45 (.87)	54	86	0	12	4.30 (.72) <sup>a</sup>
Turkey	129	11.66 (.70)	-.49 (.91)	56	6	89	4	3.41 (.27)
Balkan Countries	100	11.56 (.69)	-.39 (.97)	51	50	41	9	3.37 (.27)
Eastern Europe & former USSR	82	11.61 (.68)	-.02 (.99)	60	88	3	8	3.34 (.29)
Southern Europe	78	11.55 (.70)	-.26 (.89)	50	71	7	5	3.39 (.33)
Middle East & North Africa	43	11.67 (1.21)	-.63 (.94)	35	7	69	17	3.43 (.21)
W. Europe & N. America	20	11.40 (.50)	.51 (.76)	55	89	0	11	3.25 (.42)
Asia	19	11.42 (.61)	-.53 (.94)	42	29	0	35	3.31 (.32)
Sub Saharan Africa	12	11.42 (.51)	-.40 (.97)	67	67	8	17	3.28 (.26)
Latin America & Caribbean	7	11.86 (.90)	-.25 (1.06)	29	71	0	14	3.39 (.36)

Note: SES = combined socio-economic status of the family, PCD = perceived cultural distance. Groups ordered by group size. <sup>a</sup> For the German children, the score for perceived cultural distance is the average of their perceived distance from the seven biggest immigrant groups in Germany.

### Analyses of Friendship Networks

To obtain an overall picture of which groups are more or less frequently engaging in interethnic friendships between individual group members and to what extent friendship clusters reflect cultural similarity between regional groups (hypothesis 1), hierarchical cluster analyses were employed by clustering the ten regions. We first computed a 10 × 10 matrix containing the frequencies of friendship nominations made by individuals of each regional group (sender) towards individuals of each regional group, including their own (receiver). Based on nominations made by each regional group and controlling for regional group size, regional groups were then clustered, using squared Euclidean distances as the association measure. Individual clusters represent regional groups with the highest number of friendship nominations between them (Figure 1).

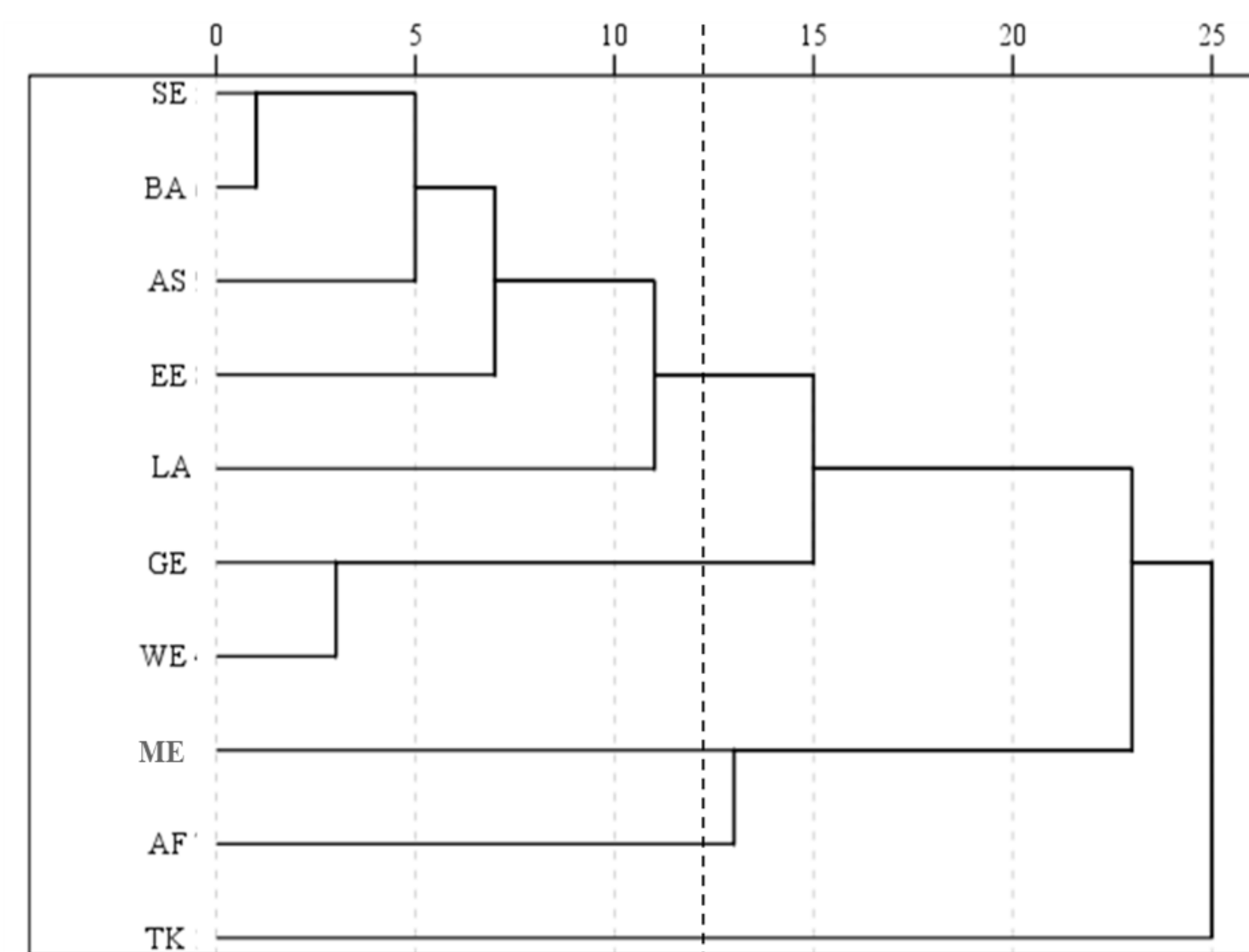

Figure 1

Dendrogram showing hierarchical clustering of regions by the occurrence of interethnic friendships between them.

Black dotted line marks cut-off point for clustering. GE = Germany, TK = Turkey, BA = Balkan countries, EE = Eastern Europe and former USSR, SE = Southern Europe, ME = Middle East and North Africa, WE = Western Europe and North America, AS = Asia, AF = Sub Saharan Africa, LA = Latin America and Caribbean.

The dendrogram suggested a five-cluster solution. The first cluster comprised Southern Europe, the Balkan countries, Asia, Eastern Europe and former USSR, and Latin America and the Caribbean. The second cluster comprised Germany and Western Europe and North America. The Middle East and North Africa, Sub Saharan Africa, and Turkey each formed distinct clusters. As expected, clustering seemed to reflect cultural similarity to some extent, with the Southern European regions (Southern Europe and the Balkan) and the Western European regions (Germany and Western Europe and North America) joining most quickly and regions expected to be culturally most distant from Europe joining much later (with the exception of Asia, which forms part of the first cluster). The fact that Turkey and the Middle East and North Africa as the two predominantly Muslim regions as well as Sub-Saharan Africa form distinct clusters suggests that children from these regions are quite isolated from the other groups.

In the next step, we assessed the likeability of regional groups amongst children from all other groups and how this reflects the ethnic hierarchy (hypothesis 2). We conducted loglinear analyses to examine the specific friendship preferences of individuals within the ten regions (region of sender and region of receiver were the independent variables) and to detect preference and non-preference patterns. We first calculated a main effects model by estimating frequencies for every possible combination in the matrix based on



the total number of listings received and made by every group, controlling for group size. This model revealed a poor fit ( $\chi^2(81, N = 842) = 529.72, p < .001$ ), suggesting the presence of an interaction between senders and receivers. We then looked for deviances from this pattern (*i.e.*, if the observed frequency in a particular cell was above or below the main effects) by checking the standardized residuals for every possible combination of sender and receiver. Positive values above 2 were taken as a significant preference by group A for group B, whereas negative values below -2 were classified as a significant non-preference by group A against group B (see Table 2).

**Table 2**  
*Standardized Residuals Showing Preferences and Non-preferences by Region*

Nominations received by region	Nominations made by region									
	GE	TK	ME	WE	SE	BA	AF	EE	AS	LA
Germany (GE)	<b>10.77</b>	<b>-6.82</b>	<b>-4.44</b>	0.77	<b>-3.47</b>	<b>-3.17</b>	<b>-1.37</b>	<b>-2.74</b>	<b>-1.88</b>	0.01
Turkey (TK)	<b>-6.74</b>	<b>8.37</b>	0.64	<b>-1.25</b>	<b>2.32</b>	<b>2.22</b>	<b>0.52</b>	<b>-1.83</b>	<b>0.40</b>	<b>1.68</b>
Middle East and North Africa (ME)	<b>-3.87</b>	<b>0.91</b>	<b>3.70</b>	<b>-1.11</b>	<b>0.28</b>	<b>1.58</b>	<b>-0.19</b>	<b>2.88</b>	<b>0.56</b>	<b>-1.17</b>
Western Europe and North America (WE)	<b>0.77</b>	<b>-1.02</b>	<b>-1.24</b>	<b>-0.83</b>	<b>0.24</b>	<b>0.04</b>	<b>-1.08</b>	<b>0.36</b>	<b>2.08</b>	<b>-0.84</b>
Southern Europe (SE)	<b>-3.67</b>	<b>1.62</b>	<b>-0.55</b>	<b>0.06</b>	<b>1.65</b>	<b>1.12</b>	<b>-1.24</b>	<b>3.20</b>	<b>1.42</b>	<b>-1.10</b>
Balkan Countries (BA)	<b>-3.97</b>	<b>0.88</b>	<b>2.54</b>	<b>1.38</b>	<b>1.55</b>	<b>2.43</b>	<b>-0.01</b>	<b>0.57</b>	<b>-0.71</b>	<b>0.69</b>
Sub Saharan Africa (AF)	<b>-0.93</b>	<b>1.21</b>	<b>0.66</b>	<b>-1.17</b>	<b>-0.49</b>	<b>-0.66</b>	<b>0.31</b>	<b>1.07</b>	<b>0.67</b>	<b>0.83</b>
Eastern Europe and former USSR (EE)	<b>-2.12</b>	<b>-0.80</b>	<b>3.43</b>	<b>-0.37</b>	<b>0.73</b>	<b>-0.49</b>	<b>2.79</b>	<b>1.60</b>	<b>0.95</b>	<b>-0.55</b>
Asia (AS)	<b>-1.38</b>	<b>1.49</b>	<b>1.16</b>	<b>0.89</b>	<b>0.52</b>	<b>-1.60</b>	<b>2.09</b>	<b>0.31</b>	<b>0.29</b>	<b>-0.75</b>
Latin America and Caribbean (LA)	<b>-0.80</b>	<b>0.66</b>	<b>0.11</b>	<b>0.12</b>	<b>-0.71</b>	<b>0.82</b>	<b>0.77</b>	<b>0.25</b>	<b>0.22</b>	<b>-0.52</b>
Mean out-group nominations made	<b>-2.52</b>	<b>-0.21</b>	<b>0.26</b>	<b>-0.07</b>	<b>0.11</b>	<b>-0.02</b>	<b>0.25</b>	<b>0.45</b>	<b>0.41</b>	<b>-0.13</b>
Mean nominations received from out- group	<b>-2.57</b>	<b>-0.23</b>	<b>-0.01</b>	<b>-0.08</b>	<b>0.10</b>	<b>0.32</b>	<b>0.13</b>	<b>0.40</b>	<b>0.30</b>	<b>0.16</b>
Difference nominations made and received	<b>0.04</b>	<b>0.02</b>	<b>0.27</b>	<b>0.00</b>	<b>0.01</b>	<b>-0.34</b>	<b>0.12</b>	<b>0.05</b>	<b>0.11</b>	<b>-0.29</b>

Note: Cells with absolute values above 2 show significant preferences (positive values) or non-preferences (negative values) and are printed in bold.

Friendship preferences within regional groups are displayed on the diagonal, with values above 2 indicating significant levels of homophily. In line with our expectation (hypothesis 2a), German children showed by far the highest level of friendship homophily. This was followed by Turkish children, children from the Middle East and North Africa, and children from the Balkan countries. The other groups did not show a significant tendency towards friendship homophily.

We then examined the likeability of different groups by examining the extent to

which friendship nominations from members of different groups were reciprocated. The means of the standardized residuals of the total out-group nominations made and received were calculated for every group. The former mean was then subtracted from the latter to assess the reciprocation rates of interethnic friendships by region. Negative values indicate that a group received more nominations than they actually made, values around zero show a balance between nominations made and received, and positive values indicate that the group made more nominations than it received (see last three rows in Table 2). Children from the Middle East and North Africa showed the highest level of unreciprocated interethnic friendships, followed by children from Sub-Saharan Africa and Asia. Children from the Balkan countries were most often nominated as a friend by children from other regions without reciprocating it, followed by children from Latin America and Caribbean. This pattern partly disconfirmed our expectation that German children would be most preferred in terms of the ratio between friendship nominations made and received (hypothesis 2b).

Next, we wanted to get a more detailed picture of the patterning of friendship preferences and non-preferences between regions (see cells off the diagonal in the top part of Table 2). German children showed significant non-preferences to children from Turkey, the Balkan countries, Middle East and North Africa and Eastern Europe and former USSR. These non-preferences were reciprocated. Concerning preferences and non-preferences between all other groups, with few exceptions the patterning was the same between listings made and listings received by children of every regional group. It seems that most of the unreciprocated preferences were going towards groups which are either expected to be of higher status in the hierarchy or larger in terms of numeric size (which can be viewed as the more powerful groups in the school context).

## Discussion

The aim of the present study was to explore early adolescents' intra- and interethnic friendship patterns and the relative likeability of different ethnic groups against the background of Social Identity Theory (Tajfel & Turner, 1986) and research on perceived cultural distance (Galchenko & Van de Vijver, 2007; Hagendoorn, 1995). We expected that these patterns would be following principles of similarity and status, with more friendships occurring between culturally similar groups (hypothesis 1) and a stronger preference for children from cultural groups ranking higher in the ethnic hierarchy (hypothesis 2). These expectations were largely confirmed. In the following, we first discuss our findings in more detail, then we point out some limitations of our research, as well as implications for future research and application.

In line with our expectation (hypothesis 1), we found that friendship clusters mostly emerged between groups that are culturally more similar (*e.g.*, Germany and Western Europe and North America). Turkish children and children from Middle East and North



Africa, seemingly similar culturally, were both isolated from the other groups as well as each other. There are several possible reasons for this. On the one hand, this may be rooted in the high levels of homophily amongst the Turkish children, who form by far the biggest and most homogeneous immigrant group. On the other hand, this may also reflect an interaction between the different proportion of males in the two groups and the high preference for same-sex friends in this age group (Aboud *et al.*, 2003), which was also observed in our sample. Finally, there may also be more substantive reasons for why children from these two groups do not befriend each other a lot. Historically, there have been many conflicts between Turkey and the Middle East (Jung, 2005). These tensions may also have affected the relationship between Turkish and Arab immigrant communities in Germany.

In line with hypothesis 2, the three groups that were most isolated, children from Middle East and North Africa, Sub-Saharan Africa, and Asia, were at the bottom of the ethnic hierarchy (Hagendoorn, 1995; Jäckle, 2008) and therefore least likely to be chosen as friends by children from regions higher up in the hierarchy. Yet, it is surprising that the children who appeared to be most preferred as friends were not German, but instead were children from Latin America and the Caribbean and the Balkans. Children from the Balkan countries are relatively well adapted compared to other immigrant groups (OECD, 2006) and form one of the biggest groups in our sample. They can therefore be expected to have a relatively high status as compared to other immigrant groups. Given German children's high level of homophily, for other immigrant children the Balkan group may provide the highest status and most accessible alternative to befriending German children. It appears that they are especially preferred by children from the Middle East and North Africa. As the Balkan region comprises a high proportion of Muslims, the common religion may be the driving factor here. Indeed, religion has been identified as an important factor driving interethnic friendships in this age group (Windzio & Wingers, 2014). The high likeability of children from the Balkans also corresponds to findings from Austria, which has an immigrant population similar to Germany (Strohmeier & Spiel, 2003).

Confirming hypothesis 2a, children from Germany showed the highest level of homophily when group size is controlled. Homophily is also high amongst children from Turkey, Middle East and North Africa and the Balkans. There are several possible explanations for this. With regards to German children and children from the Balkans, this supports the idea derived from Social Identity Theory (Tajfel & Turner, 1986) that high-status groups are reluctant to engage with members of lower-status groups in order to maintain their status. Concerning the Turkish children, the high level of homophily may also reflect the homogeneity of the group compared to the other regional groups, which each include several countries of origin. Finally, following the rejection-identification hypothesis (Branscombe *et al.*, 1999), the preference to make friends within one's own group may also be heightened in the predominantly Muslim groups as a reaction

to the high level of stigmatisation of Muslims in most Western societies (Zick & Küpper, 2009). This stigmatisation is also experienced by adolescent Muslim immigrants and has been associated with high levels of religious affirmation and ethnic maintenance (Güngör, Bornstein, & Phalet, 2012).

In contradiction to hypothesis 2b, German children did not receive more friendship nominations from members of other groups than they made to members of these groups. German children's preference for homophily may still be the driving factor regarding interethnic friendships with immigrants; immigrant children simply may not nominate German children, as they know the friendship would not be reciprocated. Previous research has shown that a German orientation toward homophily can be interpreted by immigrant youth as discriminatory, which might even elicit an aversive reaction (Brenick, Titzmann, Michel, & Silbereisen, 2012).

### Limitations and Future Directions

Although we could provide interesting insights into early adolescents' inter- and intraethnic friendships, it needs to be emphasised that our study was mainly exploratory. There are several limitations, which should be mentioned in particular. Firstly, although we are not aware of a study looking at friendship networks in so many different ethnic groups, some of these groups in our sample were only comprised of very few participants. Findings concerning these groups therefore have to be taken with some caution and should be replicated with larger subsamples. Secondly, it would be interesting to replicate these findings with a network analysis program in order to conduct more sophisticated analyses and also include predictors for inter- and intraethnic friendships. Thirdly, deeper insights into the process of friendship formation between members of different groups would require longitudinal data.

### Conclusion and Implications

Overall, both similarity (in terms of low cultural distance) and status (in terms of a group's position in the ethnic hierarchy) seem to play a role in the formation of early adolescents' inter- and intraethnic friendships. Since the two are often related, it is difficult to establish their unique associations with the patterns observed. Longitudinal and experimental research could help to get a clearer picture of these unique effects. Regardless of these unique effects, our findings suggest that perceptions of cultural distance, which also underlie the ethnic hierarchy, provide a suitable target for interventions to improve interethnic relations in early adolescence. On the one hand, learning about cultural differences may make them less threatening and easier to bridge in social relationships. Schools provide many opportunities here, both as part of the curriculum and the school culture and climate. On the other hand, experiencing different kinds of social groups and hierarchies may make ethnic groups and hierarchies less salient. Shifting roles and responsibilities as well as seating and working arrangements within the school



context may be measures towards this.

### Author note

This study was funded by the federal program “ProExzellenz” of the Free State of Thuringia, Germany, which also provided scholarships to the first and third author at the Graduate School of Human Behaviour in Social and Economic Change at the Friedrich Schiller University Jena.

### References

- Aboud, F. E., Mendelson, M. J., & Purdy, K. T. (2003). Cross-race peer relations and friendship quality. *International Journal of Behavioral Development, 27*(2), 165-173. doi: 10.1080/01650250244000164
- Arends-Tóth, J., & Van de Vijver, F. J. R. (2007). Acculturation attitudes: A comparison of measurement methods. *Journal of Applied Social Psychology, 37*(7), 1462-1488. doi: 10.1111/j.1559-1816.2007.00222.x
- Baerveldt, C., Zijlstra, B., De Wolf, M., Van Rossem, R., & Van Duijn, M. A. J. (2007). Ethnic boundaries in high school students' networks in Flanders and the Netherlands. *International Sociology, 22*(6), 701-720. doi: 10.1177/0268580907082248
- Bellmore, A. D., Nishina, A., Witkow, M. R., Graham, S., & Juvonen, J. (2007). The influence of classroom ethnic composition on same- and other-ethnicity peer nominations in middle school. *Social Development, 16*(4), 720-740. doi: 10.1111/j.1467-9507.2007.00404.x
- Bos, W., Lankes, E.-M., Prenzel, M., Schwippert, K., Walther, G., & Valtin, R. (2003). *Erste Ergebnisse aus IGLU. Schülerleistungen am Ende der vierten Jahrgangsstufe im internationalen Vergleich [First results from IGLU. International comparison of student performance at the end of primary school]*. Münster: Waxmann.
- Boyce, W., Torsheim, T., Currie, C., & Zambon, A. (2006). The family affluence scale as a measure of national wealth: validation of an adolescent self-report measure. *Social Indicators Research, 78*(3), 473-487. doi: 10.1007/s11205-005-1607-6
- Branscombe, N. R., Schmitt, M. T., & Harvey, R. D. (1999). Perceiving pervasive discrimination among African Americans: Implications for group identification and well-being. *Journal of personality and social psychology, 77*(1), 135-149. doi: 10.1037/0022-3514.77.1.135
- Brenick, A., Titzmann, P. F., Michel, A., & Silbereisen, R. K. (2012). Perceptions of discrimination by young diaspora migrants. *European Psychologist, 17*(2), 105-119. doi: 10.1027/1016-9040/a000118
- Central Intelligence Agency. (2012). *The World Fact Book*. Retrieved 14/02/2012, from <https://www.cia.gov/library/publications/the-world-factbook/>
- Galchenko, I., & Van de Vijver, F. J. R. (2007). The role of perceived cultural distance in the acculturation of exchange students in Russia. *International Journal of Intercultural Relations, 31*(2), 181-197. doi: 10.1016/j.ijintrel.2006.03.004
- Güngör, D., Bornstein, M. H., & Phalet, K. (2012). Religiosity, values, and acculturation. *International Journal of Behavioral Development, 36*(5), 367-373. doi: 10.1177/0165025412448357
- Güngör, D., Fleischmann, F., Phalet, K., & Maliepaard, M. (2013). Contextualizing religious acculturation: Cross-cultural perspectives on Muslim minorities in Western Europe. *European Psychologist, 18*(3), 203-214.
- Hagendoorn, L. (1995). Intergroup biases in multiple group systems: The perception of ethnic hierarchies. *European Review of Social Psychology, 6*(1), 199-228. doi: 10.1080/14792779443000058
- Hamm, J., Brown, B. B., & Heck, D. J. (2005). Bridging the ethnic divide: Student and school characteristics in African American, Asian-descent, Latino, and white adolescents' cross-ethnic friend nominations. *Journal of Research on Adolescence, 15*(1), 21-46. doi: 10.1111/j.1532-7795.2005.00085.x
- Jäckle, N. (2008). *Die Ethnische Hierarchie in Deutschland und die Legitimierung der Ablehnung und Diskriminierung ethnischer Minoritäten - Über den Konsens in den individuellen Vorurteilen von Mitgliedern einer Gesellschaft*. (Doctoral Thesis), Philipps-Universität Marburg, Marburg / Lahn. Retrieved from <http://archiv.ub.uni-marburg.de/diss/z2008/0475/pdf/dnj.pdf>
- Jugert, P., Noack, P., & Rutland, A. (2012). Children's cross-ethnic friendships: Why are they less stable than same-ethnic friendships? *European Journal of Developmental Psychology, 10*(6), 649-662. doi: 10.1080/17405629.2012.734136
- Jung, D. (2005). Turkey and the Arab World: Historical Narratives and New Political Realities. *Mediterranean Politics, 10*(1), 1-17. doi: 10.1080/1362939042000338818
- Killen, M., & Rutland, A. (2011). *Children and Social Exclusion: Morality, Prejudice and Group Identity*. Oxford, UK: Blackwell.
- McPherson, M., Smith-Lovin, L., & Cook, J. M. (2001). Birds of a feather: Homophily in social networks. *Annual Review of Sociology, 27*, 415-444. doi: 10.2307/2678628
- OECD. (2006). *Where immigrant students succeed: A comparative review of performance and engagement in PISA 2003*. Retrieved from <http://www.oecd.org/education/school/programmeforinternationalstudentassessmentpisa/whereimmigrantstudentsucceed-acomparativereviewofperformanceandengagementinpisa2003.htm>
- Phalet, K., & Hagendoorn, L. (1996). Personal adjustment to acculturative transitions: The Turkish experience. *International Journal of Psychology, 31*(2), 131-144. doi: 10.1080/002075996401142
- Richter, M., & Leppin, A. (2007). Socioeconomic inequalities in health: Trends in socio-economic differences in tobacco smoking among German school children, 1994–2002. *The European Journal of Public Health, 17*(6), 565-571. doi: 10.1093/eurpub/ckm010
- Schachner, M. K., Brenick, A., Noack, P., Van de Vijver, A. J. R., & Heizmann, B. (2014). *Structural and normative conditions for interethnic friendships in multiethnic classrooms*. Manuscript submitted for publication.
- Statistisches Bundesamt. (2013). Bevölkerung mit Migrationshintergrund - Ergebnisse des Mikrozensus 2012. *Fachserie 1, Reihe 2.2*.
- Strohmeier, D., & Spiel, C. (2003). Immigrant children in Austria. *Journal of Applied School Psychology, 19*(2), 99-116. doi: 10.1300/J008v19n02\_07
- Tajfel, H., & Turner, J. C. (1986). The social identity theory of intergroup behaviour. In S. Worchel & W. G. Austin (Eds.), *Psychology of intergroup relations* (pp. 7-24). Chicago, IL: Nelson-Hall.
- Te Lindert, A., & Van de Vijver, F. J. R. (2010). *The role of ethnic hierarchy and cultural distance in acculturation among Dutch immigrants*. Paper presented at the XXth Congress of the International Association of Cross-Cultural Psychology, Melbourne.
- Titzmann, P., Brenick, A., & Silbereisen, R. K. (2014). *A longitudinal analysis of intergroup relations between native Germans and ethnic minority immigrants in Germany*. Manuscript submitted for publication.
- Verkuyten, M. (2002). Perceptions of ethnic discrimination by minority and majority early adolescents in the Netherlands. *International Journal of Psychology, 37*(6), 321-332. doi: 10.1080/00207590244000142
- Verkuyten, M., Hagendoorn, L., & Masson, K. (1996). The ethnic hierarchy among majority and minority youth in the Netherlands. *Journal of Applied Social Psychology, 26*(12), 1104-1118. doi: 10.1111/j.1559-1816.1996.tb01127.x
- Vervoort, M. H. M., Scholte, R. H. J., & Scheepers, P. L. H. (2011). Ethnic composition of school classes, majority–minority friendships, and adolescents' intergroup attitudes in the Netherlands. *Journal of adolescence, 34*(2), 257-267. doi: 10.1016/j.adolescence.2010.05.005
- Vyas, S., & Kumaranayake, L. (2006). Constructing socio-economic status indices: how to use principal components analysis. *Health Policy and Planning, 21*(6), 459-468 doi: 10.1093/heapol/czl029
- Windzio, M., & Wiggins, M. (2014). Religion, friendship networks and home visits of immigrant and native children. *Acta Sociologica, 57*(1), 59-75. doi: 10.1177/0001699313481226
- Zick, A., & Küpper, B. (2009). Meinungen zum Islam und Muslimen in Deutschland und Europa [Opinions on Islam and Muslims in Germany and Europe] *Ausgewählte Ergebnisse der Umfrage Gruppenbezogene Menschenfeindlichkeit in Europa [Selected results of the Group-Focussed Enmity survey in Europe]*. Bielefeld, Germany: Universität Bielefeld.